



# **Centaurus Linebacker 100 & 250 Watt Models**

Service Questions Call: 910-259-1131

## **IMPORTANT SAFEGUARDS**

When using electrical equipment, basic safety precautions should always be followed, including the following:

### **READ AND FOLLOW ALL SAFETY INSTRUCTIONS**

All servicing should be performed by qualified personnel only.

Equipment should be mounted in locations and at heights where it will not be readily subjected to tampering by unauthorized personnel.

The use of accessory equipment not recommended by the manufacturer may cause an unsafe condition.

Do not use this equipment for other than intended use.

Do not use outdoors.

Do not let supply cords touch hot surfaces.

Do not mount near gas or electric heaters.

Use caution when servicing batteries. Battery acid can cause burns to skin and eyes. If acid is spilled on skin or eyes, flush acid with fresh water and contact a physician immediately.



## **INSTALLATION AND OPERATING INSTRUCTIONS**

**CAUTION:** To avoid electrical overload, total connected lamp load (factory and field installed) should not exceed output rating.

### **SAVE THESE INSTRUCTIONS**

**WARNING** – Shut off AC power to branch circuits to which units will be connected. All wiring should be per N.E.C. Articles 501-4(b) and local codes.

To maintain warranty, equipment with batteries must be installed or placed on charge within prescribed period after shipment.

### **GENERAL INSTRUCTIONS**

## MODEL LB100 MOUNTING INSTRUCTIONS

### **SURFACE (S) MODELS**

- Remove front cover and any packing material inside the unit housing that may have been used for shipping purposes.
- Remove the appropriate knockout on the right side of the unit housing for the utility wiring connector being used. Also remove the two keyhole mounting knockouts in the upper corners on the back of the housing.
- Secure housing to the mounting surface through the keyhole knockouts using mounting hardware (not supplied) sized appropriately to hold the unit weight.

### **CEILING GRID (T) MODELS**

- Remove side cover and any packing material inside the unit housing that may have been used for shipping purposes.
- PCF Series Ceiling Grid models are designed for drop-in installation in suspended ceiling grid systems. Mount the equipment securely in place between ceiling T-Grid members. **NOTICE:** Safety chain or wire must be installed to support the weight of the unit. *Failure to install safety chain or wire will cause an unsafe condition.* Holes are provided at each end of the housing for connecting safety chain or wire.
- Remove the unit battery (if installed) and the appropriate mounting pattern knockouts in the unit housing to accommodate the electrical box screws. Also remove the round center wire pass knockout in the mounting pattern. If electrical box is not being used for utility connection, wire utility directly through knockout on either end of the unit housing using approved connector (installer supplied).

### **RECESSED WALL OR CEILING (R) MODELS**

- Detach the trim plate by removing the two screws that secure it to the unit housing. **NOTE:** Remove any packing material inside the unit housing that may have been used for shipping purposes.
- Remove the unit battery and the appropriate mounting knockout in the top or sides of the unit housing for attachment of utility wiring connector (installer supplied).

## MODEL LB250 SURFACE MOUNTING INSTRUCTIONS

- Remove front cover and any packing material inside the unit housing that may have been used for shipping purposes.
- Remove the appropriate knockout on the right side of the unit housing for the utility wiring connector being used. Also remove the two keyhole mounting knockouts in the upper corners on the back of the housing.
- Secure housing to the mounting surface through the keyhole knockouts using mounting hardware (not supplied) sized appropriately to hold the unit weight.

**NOTE:** Batteries for LB250 models are shipped separately see “Battery Connections” for installation details.

**IMPORTANT:** Before connecting the AC input wires you must determine how the connected emergency lighting fixtures are to operate; **Normally-On** all the time, **Normally-Off** and only come on during a power failure, or **Switched** on/off.

Wire according to the appropriate following section. Connect ground wire in accordance with local codes.



# WIRING INSTRUCTIONS (Normally-Off and Switched Operation)

## Normally-Off Load: (Fixture illuminates only upon loss of utility power)

- CAUTION:** Make sure branch circuit breaker is open.
- Disconnect both the black\*, and orange\* transformer leads from the PC board labeled "24 HOUR UNSWITCHED CHARGER AC INPUT SUPPLY". **CAUTION: Disconnect only the labeled black and orange leads. Use of unlabeled black and orange leads will cause an unsafe condition and damage unit.** Cut off spade terminals from wire ends and splice appropriate lead to unswitched AC input; choosing either **black** for 120 volt operation or **orange** for 277 volt operation. Insulate unused wire. Connect unswitched AC input neutral to terminal post TB1-4 (See Figure 3 or Figure 4 below).

## Switched Loads: (Fixture can be turned on and off from a local switching device and will illuminate upon loss of utility power, regardless of the local switch's position)

- CAUTION:** Make sure branch circuit breaker is open.
- Disconnect both the black\*, and orange\* transformer leads from the PC board labeled "24 HOUR UNSWITCHED CHARGER AC INPUT SUPPLY". **CAUTION: Disconnect only the labeled black and orange leads. Use of unlabeled black and orange leads will cause an unsafe condition and damage unit.** Cut off spade terminals from wire ends and splice appropriate lead to unswitched AC input; choosing either **black** for 120 volt operation or **orange** for 277 volt operation. Insulate unused wire. Connect input neutral to terminal TB1-4 (See Figure 3 or Figure 4 below).
- Connect switched input to either TB1-5 for 120 volts, or TB1-6 for 277 volts (See Figure 3 or 4 below).
- In operation, the local switching device will be able to turn the fixture on and off, but the fixture will illuminate whenever power is lost, regardless of the local switch position.

\*Brown wire may be substituted for special voltages/frequencies.

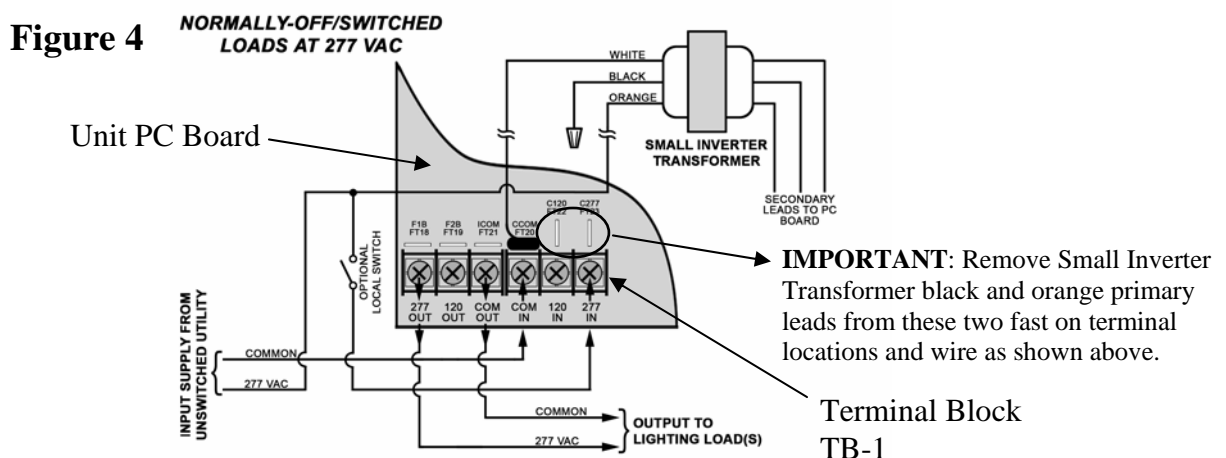
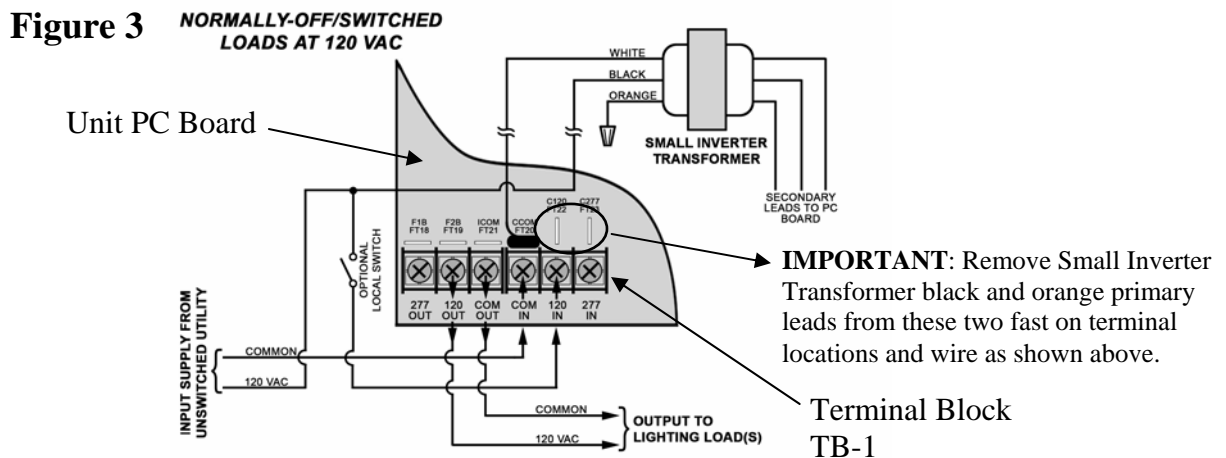

## BATTERY CONNECTIONS

**LB100 Models:** Supplied with 4 batteries installed. The connections are factory made. Connect the two blue Battery Negative (–) leads and the two red Battery Positive (+) leads from the PC board to the battery terminals as shown below. Measure the voltage across the Battery Positive and Battery Negative terminals on the PC board. The reading should measure 12 volts ( $\pm 1$  volt).

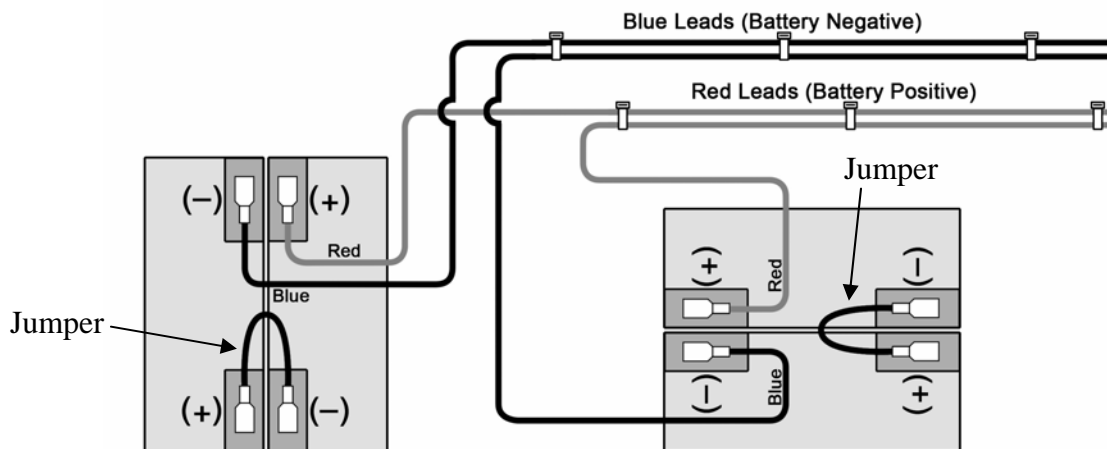

**LB250 Models:** Supplied with 2 batteries shipped separately. Install the batteries into the cabinet exactly as shown below and with the jumper wire supplied, connect the Battery Positive (+) terminal of the first battery to the Battery Negative (–) terminal of the second battery. Connect the red lead from the PC board to the open Battery Positive (+) terminal. Connect the blue lead from the PC board to the open Battery Negative (–) terminal. Measure the voltage across the Battery Positive and Battery Negative terminals on the PC board. The reading should measure 24 volts ( $\pm 1$  volt).

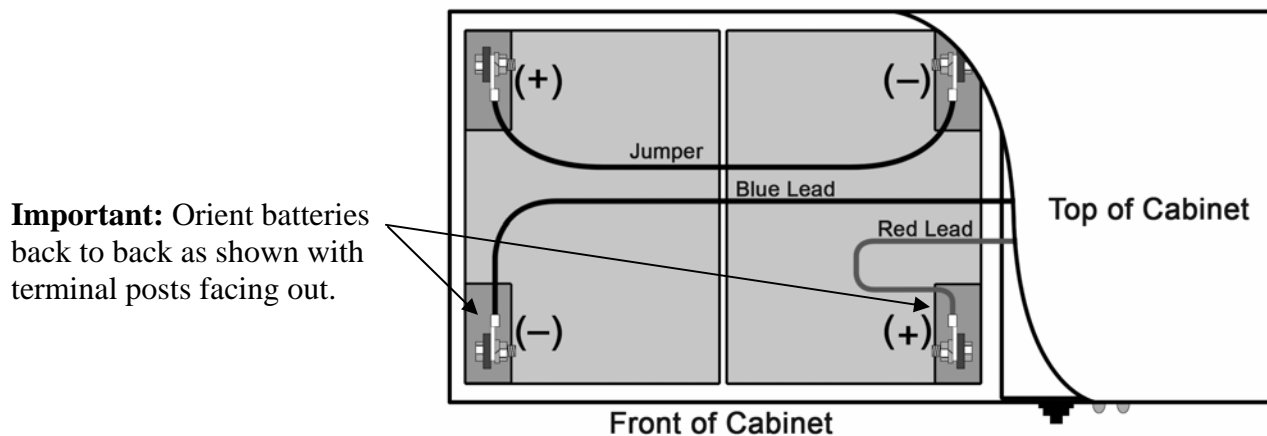

## MAINTENANCE

**Caution:** Always turn off AC power to the equipment before servicing. **Service should be performed only by qualified service technicians.** Use only manufacturer supplied replacement parts.

**Battery:** The battery supplied with this equipment requires no maintenance. However, it should be tested periodically and replaced whenever it will no longer operate the connected fixtures for the duration of a 90 minute test.

## **TESTING**

**Start-up Support: 910-259-1131 for factory help with step-by-step startup instructions.**

Paragraph 31-1.3.7 of NFPA 101- 1985, Life safety Code requires that all emergency lighting equipment be functionally tested every 30 days for a minimum of 30 seconds and tested yearly for a full 90 minute duration. Written records of testing are to be kept for examination by the authority having jurisdiction.

## **TROUBLESHOOTING**

Emergency lights do not operate:

- a. If CHARGE indicator is off: Check that circuit breaker for AC supply is on,
- b. If CHARGE indicator is on: Check that the battery is properly connected and check output fuses.

## **OUTPUT RATINGS AND REPLACEMENT PARTS**

Model Number	Voltage	Output Ratings	Batteries	
			Part No.	Quantity
LB100	12VDC	100 watts	1000010136	4
LB250	24VDC	250 watts	1000010229	2