

PENDANT STEM KIT FOR WET LOCATION CAST EXIT

NOTE: Both the outlet box and the exit frame must be grounded to the service ground.

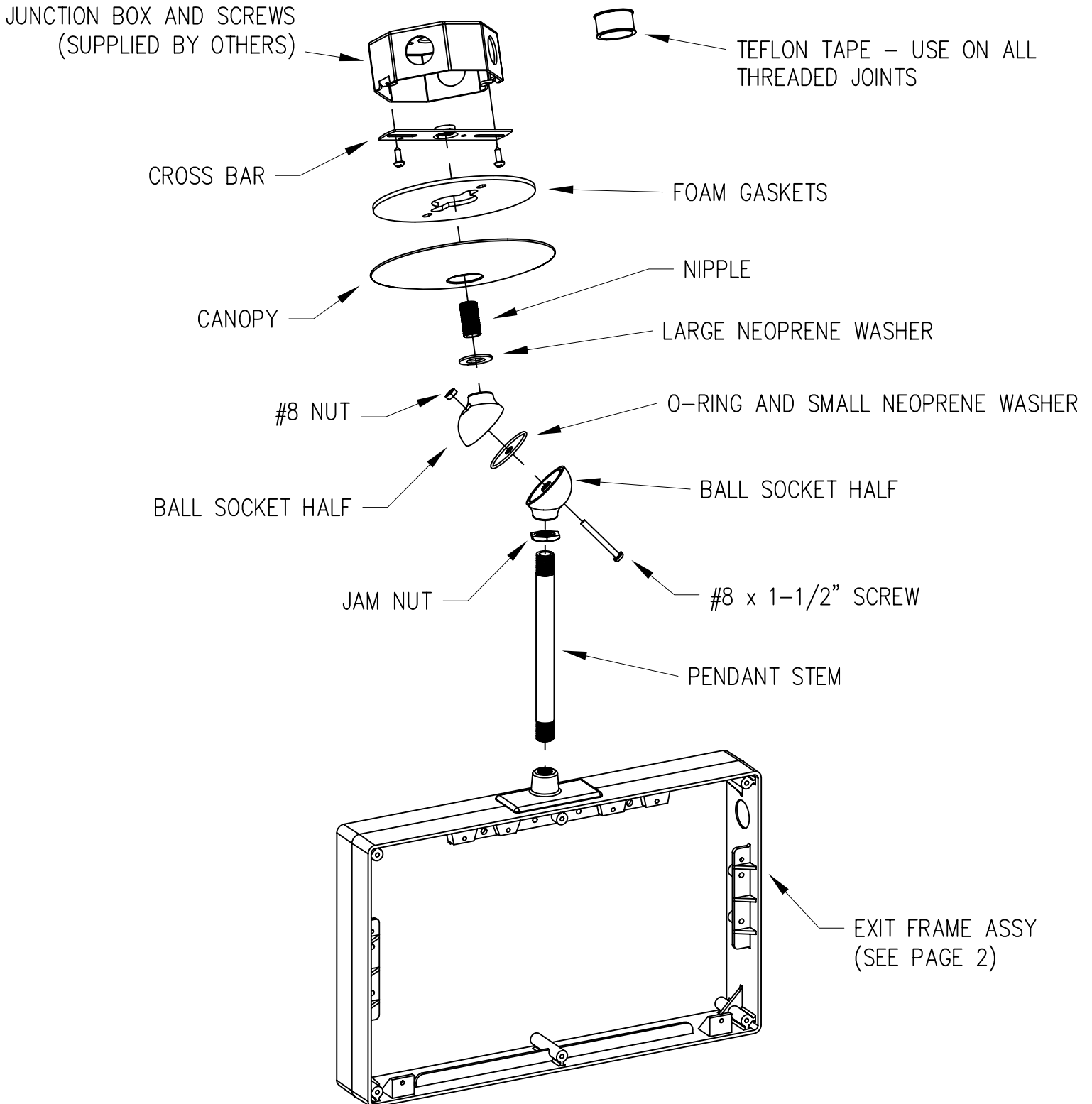

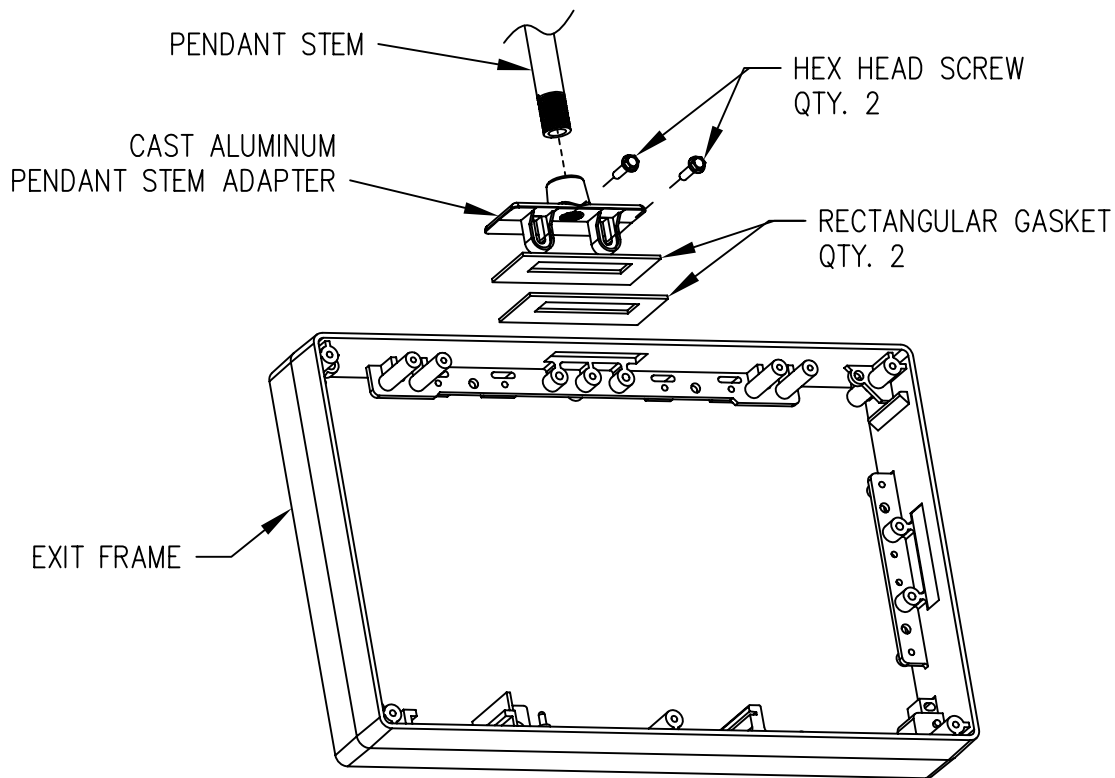

Remove knockout in top of exit frame. Peel and stick both gaskets to the bottom of the cast aluminum pendant adapter. Insert legs of pendant adapter into exit frame and attach using two #8 hex head screws provided. Thread AC service wires from pendant stem through pendant stem adapter and thread exit frame/adapter assembly onto pendant stem (seal threads using thread sealant provided). Refer to table below for AC service connections.

<u>120V Input</u>		<u>277V Input</u>
Black wire to line	<u>OR</u>	Blue wire to line
White wire to common		White wire to common
Green wire to ground		Green wire to ground
Unused primary wire must be insulated to prevent shorting.		