



UNISON SERIES 6 Volt, 12 to 18 Watt Lead & NiCad Batteries

Service Questions Call: 910-259-1131

IMPORTANT SAFEGUARDS

When using electrical equipment, basic safety precautions should always be followed, including the following:

READ AND FOLLOW ALL SAFETY INSTRUCTIONS

All servicing should be performed by qualified personnel only.

Equipment should be mounted in locations and at heights where it will not be readily subjected to tampering by unauthorized personnel.

The use of accessory equipment not recommended by the manufacturer may cause an unsafe condition.

Do not use this equipment for other than intended use.

Do not use outdoors.

Do not let supply cords touch hot surfaces.

Do not mount near gas or electric heaters.

Do not mount on ceiling without optional canopy kit.



INSTALLATION AND OPERATING INSTRUCTIONS

Caution: Halogen cycle lamp(s) are used in this equipment. To avoid shattering: Do not operate lamp in excess of rated voltage, protect lamp against abrasion and scratches and against liquids when lamp is operating, dispose of lamp with care.

Halogen cycle lamps operate at high temperatures. Do not store or place flammable materials near lamp.

Use caution when servicing batteries. Battery acid can cause burns to skin and eyes. If acid is spilled on skin or eyes, flush acid with fresh water and contact a physician immediately.

CAUTION: To avoid electrical overload, total connected lamp load (factory and field installed) should not exceed output rating.

SAVE THESE INSTRUCTIONS

WARNING – Shut off AC power to branch circuits to which units will be connected. All wiring should be per N.E.C. Articles 501-4(b) and local codes.

To maintain warranty, equipment with batteries must be installed or placed on charge within prescribed period after shipment.

GENERAL INSTRUCTIONS

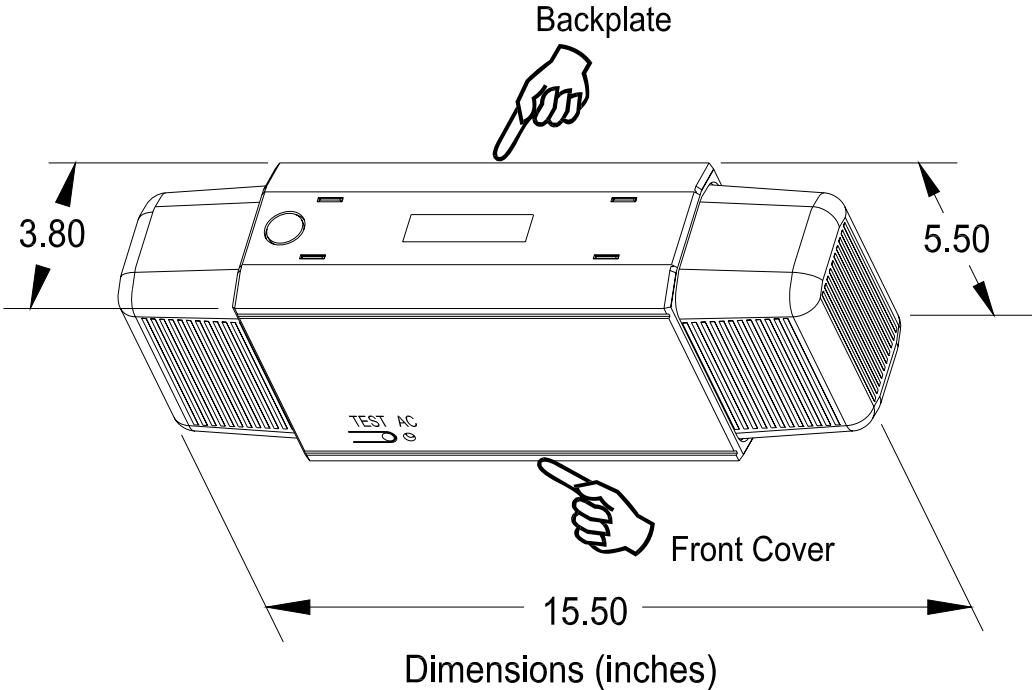

NOTE: This unit can be ceiling or wall mounted. Ceiling mounting requires optional canopy kit.

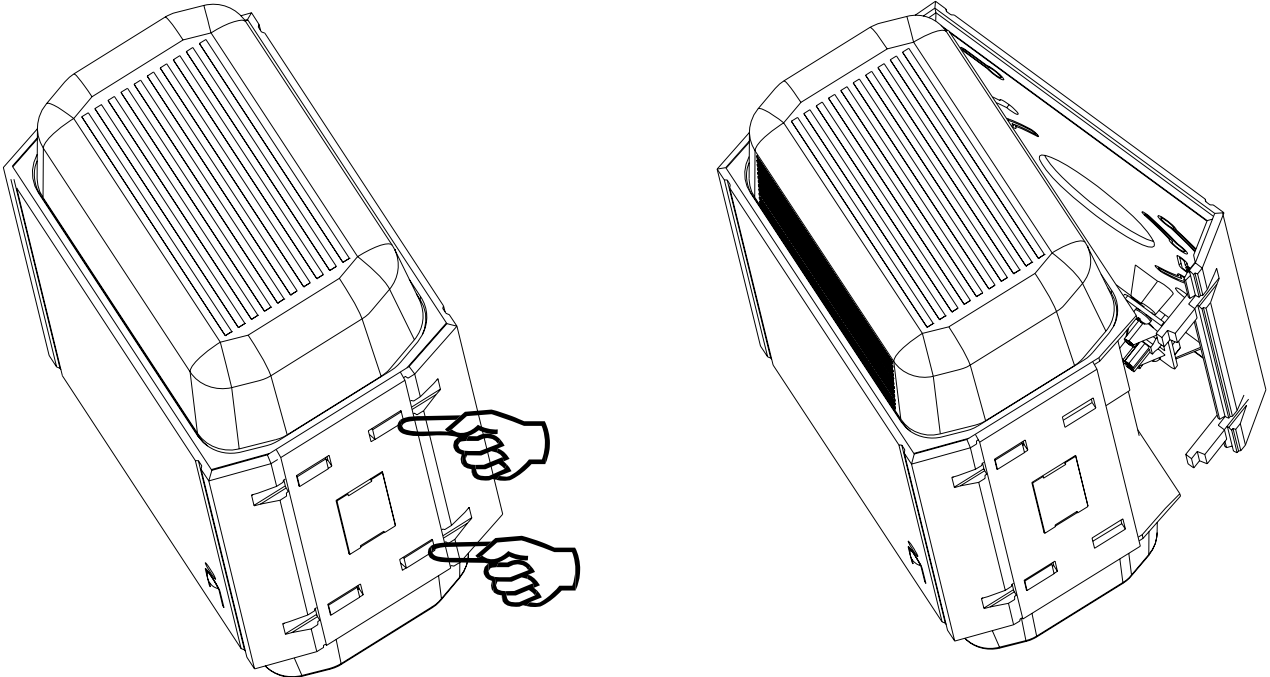

Step 1

Press in tabs on bottom of unit to release backplate. Remove backplate. Repeat for front cover. Set aside housing assembly and front cover.

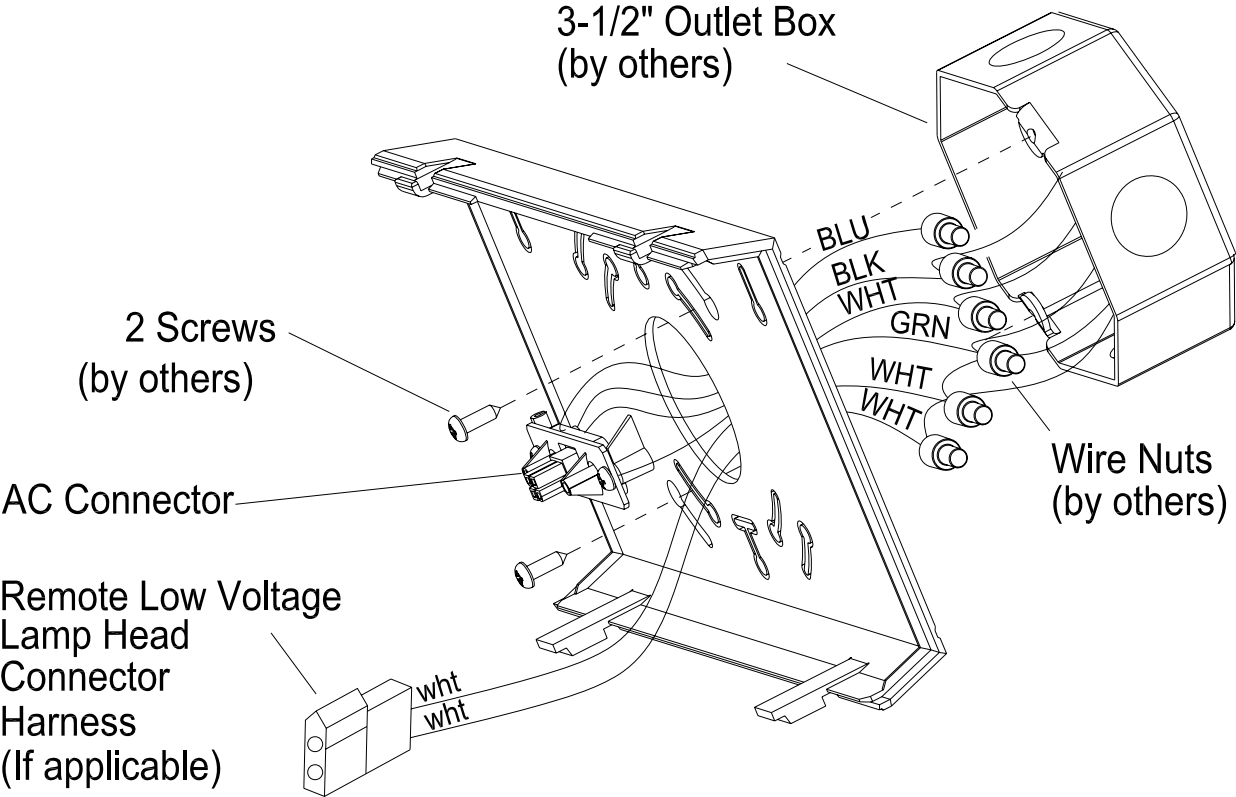

120VAC Hookup Shown Above

AC Hookup	
120VAC Operation	277VAC Operation
White wire - Common	White wire - Common
Black wire – 120V Line	Blue wire – 277V line
Green wire – ground	Green wire - ground
Unused primary wire must be insulated to prevent shorting.	

Step 2

AC Hookup –

Remove appropriate knockouts in backplate. Mount backplate to outlet box with two screws supplied by others. Pull AC service wires through hole in backplate. Make AC service connections at this time.

Remote Lamp Head Hookup (if applicable)-

Pull remote service wires through hole in backplate. Make connections to the provided remote lamp wiring harness at this time. There is no need to observe any polarity on these connections. **Note** that all remote lamp heads must be 6VDC, remote lamp heads must be connected in parallel to the provided remote lamp wiring harness and the combined wattage of the integral lamp heads and remote lamp heads must not exceed the maximum wattage output of the product. Refer to nameplate label for maximum output wattage.

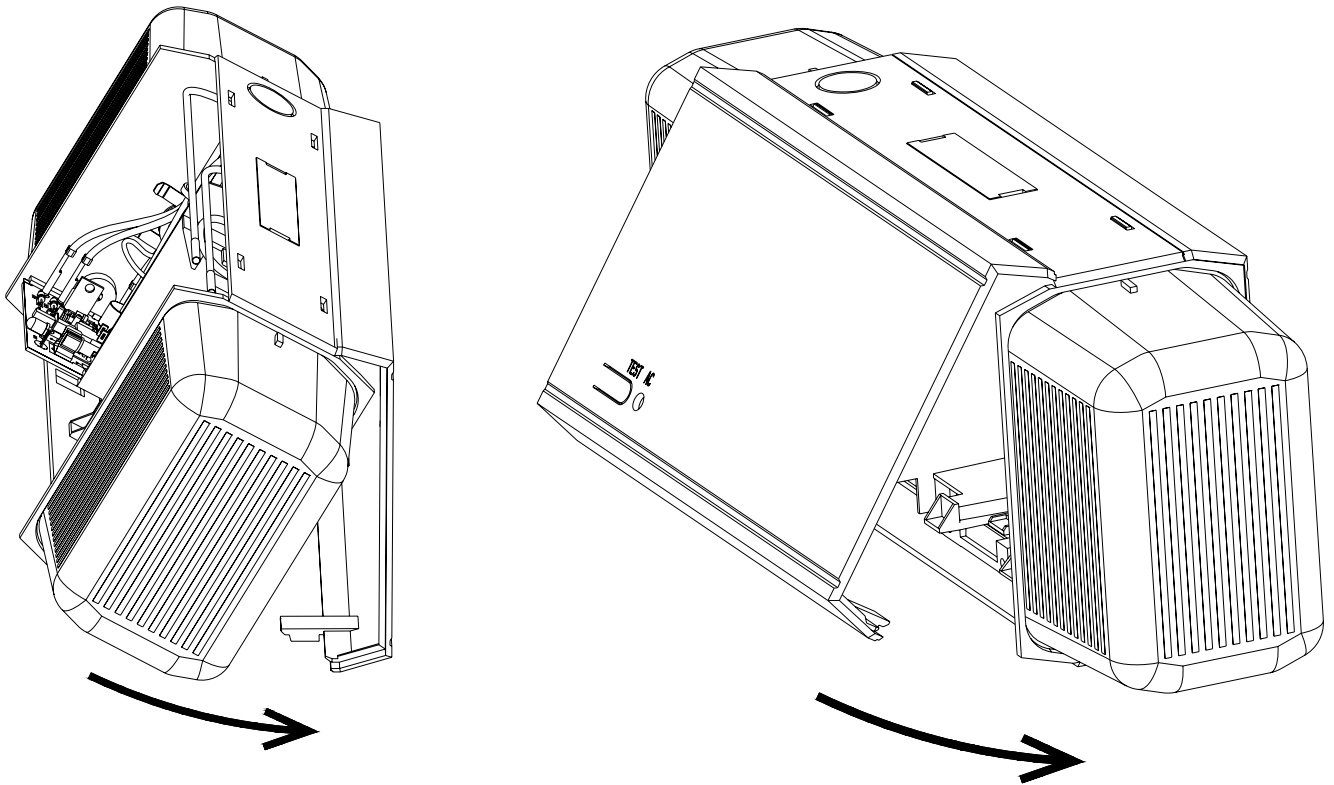

Step 3

- If your unit has a lead battery, connect the red battery wire to the (+) battery terminal. Check that the black wire is securely connected to the (-) battery terminal.
- If your unit has a NiCad battery, connect the battery quick connector at this time.
- Push excess wiring back into junction box and reassemble housing to backplate as shown in the above left view. AC supply will be connected at this time.
- Reassemble cover to housing.

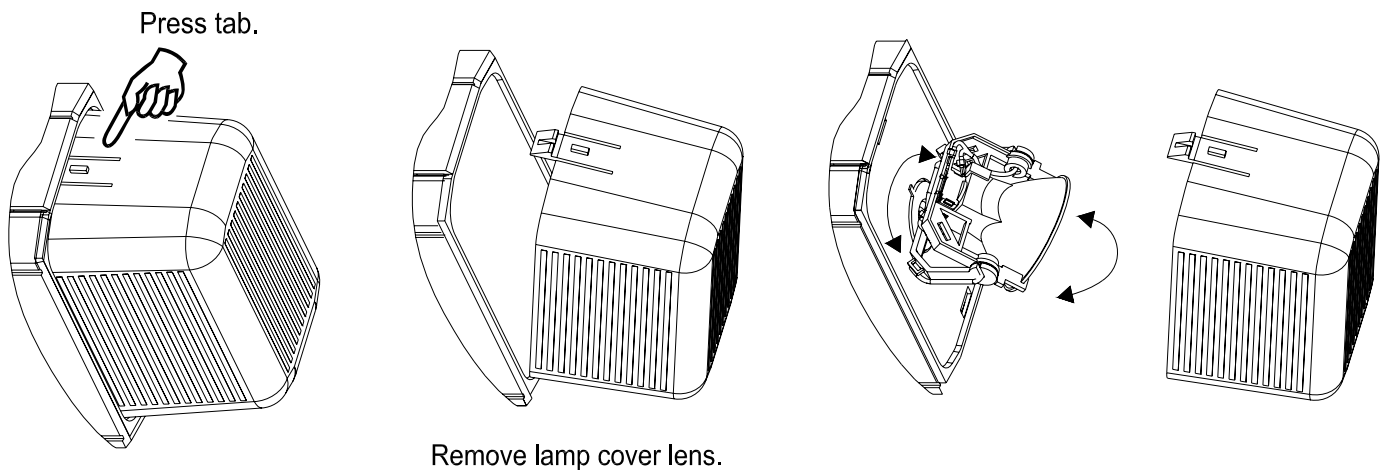

Remove lamp cover lens.

Adjust lamp to desired position and replace lamp cover lens.

Step 4

See the above sequence of pictures for lamp head aiming.

Operating Instructions

1. Energize AC power to equipment and check that pilot lamp illuminates red.
2. Press test switch and verify pilot lamp turns off and lamp heads illuminate.
3. Leave AC connected for a minimum of 24 hours before performing and extended testing. Full recharge of batteries may require one full week.

Notes:

1. This equipment is provided with a lockout feature whereby connecting battery leads prior to energizing AC power will not turn on the emergency lamps. After AC power is energized, the emergency lamps will illuminate upon AC power failure.
2. This equipment is provided with a low battery disconnect feature which prevents full discharge of the batteries. If the building is to be unoccupied for an extended period of time and AC power is shut off, the batteries should be disconnected from the charger to prevent damage.
3. The batteries provided in this equipment are sealed and require no maintenance.